



## S-FIRE SELK1500SF2

SELK1500SF2 S-FIRE LED 4 watt emergency luminaire with adaptor ring

### Application

A perfect choice for apartments or commercial spaces requiring compliance to AS/NZS 2293

### Design Specifications

- Compliant to AS/NZS2293, with an impressive D63 emergency lighting classification, non-maintained
- Polycarbonate body profile, double insulation, 72mm cut-out and includes a 145mm adaptor ring (130mm cut-out)
- 4 watt system, LED charge status display and test switch, with remote control gear and high performance integral Lithium battery
- 1.2 m flex & 3 pin plug fitted, IC-4 rated (luminaire head only), trim colour white
- Guaranteed 90 minutes emergency function. Intelligent automatic recharging function, 16 hour recharge time and deep discharge protection
- Optional surface mount kit SELK1500SF2SM/P available



### Technical Specification

Model No.	Description	Input Voltage (V/AC)	Power (W)	CCT (K)	CRI	Dim (mm)
SELK1500SF2	S-FIRE INTEGRATED LED EM LIGHT	240	4	6000	80	
SELK1500SF2SM/P	S-FIRE SURFACE MOUNT HOUSING					220(L) x 220(W) x 60(H)

Note: Battery warranty twelve (12) months

Due to continued product and technology enhancements, data sourced from sal.net.au shall not form part of any contract and or technical performance guarantee unless expressly confirmed in writing by SAL at the time of order. Products are sold in accordance with [SAL Terms and Conditions of sale](#) and all images shown are for illustration purposes only and may vary from the actual colour or finish. Unless specifically stated, all IP ratings nominated for Interior products are from "below the ceiling".

## Dimensions

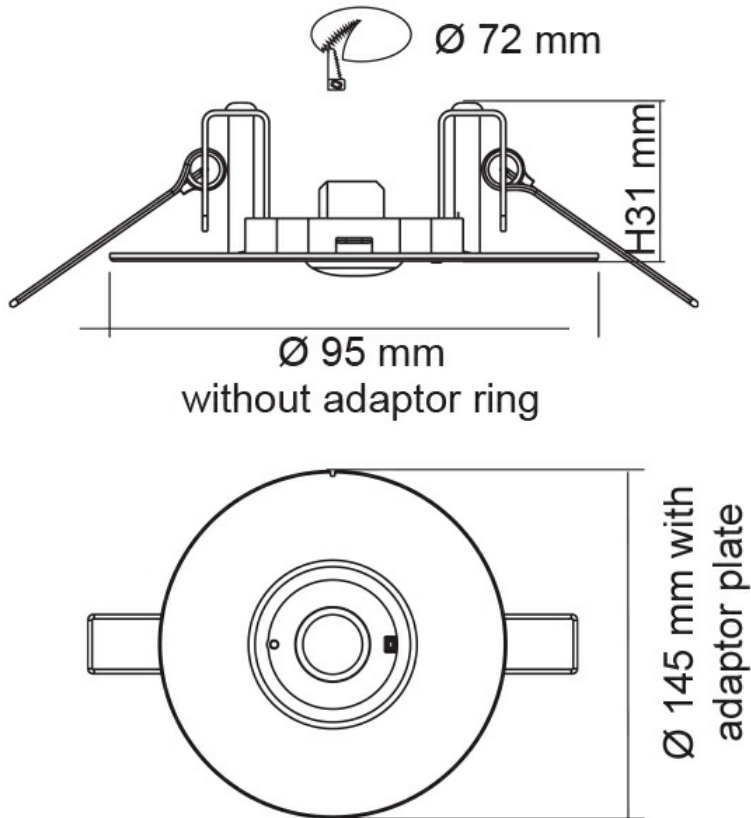

## Product Images

