



PVC Air Conditioner Mounting Ground Brackets is made of 100% new PVC raw material.

The feet are temperature resistant to high and low temperatures, and have a shockproof pad for air conditioner installation

Ground bracket Features

- Stability and universality-The ground bracket for a split air conditioner can withstand up to 200 kgs.
- Air conditioner BTU rating of 9,000 BTUs to 18,000 BTUs can be mounted.
- Protection function-The durable PVC has excellent features for the weather resistance, Anti-UV light, and corrosion resistance, operates within -10°C to 50°C.
- Precise Structure - The safety design of the guide rail groove sliding structure provides free adjustment of the screw position which allows easy fixation and installation.

Applications

Easy install your min split air conditioner.

Easy installation outside unit.

Specifications

Model	A	B	C	D	Applicable Scope
ICGAC	450	115	73	82	7500Btu-24000Btu A/C

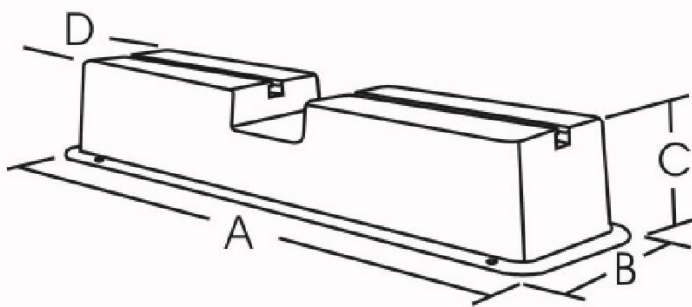

Product Code	Description	Dimensions (mm)
ICGAC	Plastic AC Mounting Feet per Pair	450x115x73x82