

LITHIUM-MANGANESE DIOXIDE BATTERY

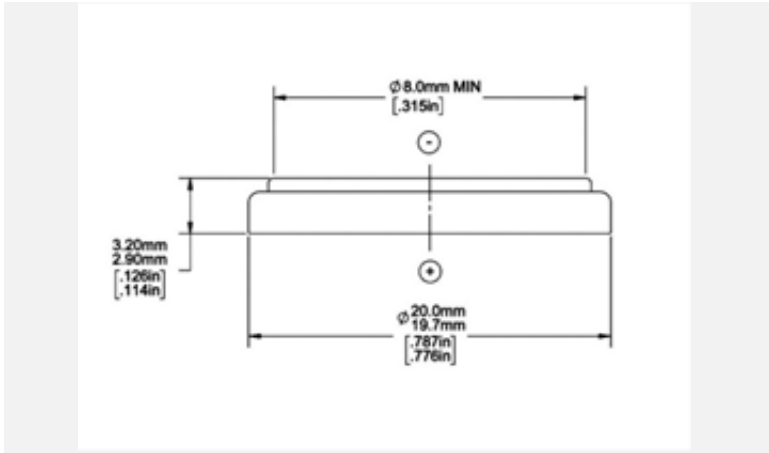

Size: DURPC2032



Dimensions shown are IEC standards

KEY FEATURES

- High voltage response, stable during most of the lifetime of the application
- Reliable Performance
- Child-Safe Markings & Retail Packaging
- Low self-discharge with long operating life (<1% after 1 year of storage at + 20 °C)
- Excellent resistance to corrosion
- Designed to meet all major quality, safety and environment standards:
 - Safety: IEC 60086-4
 - Transport: UN 38.3
 - RoHS and REACH compliance
 - Quality: ISO 9001, Duracell World Class Continuous Program



130 Bush Road
 Albany, 0632
 Telephone: 0800 239 239
www.hamer.co.nz

ELECTRICAL CHARACTERISTICS

▪ Nominal capacity (15 kΩ Cont., 2.0 V cut-off)	265 mAh
▪ Open circuit voltage (at + 20 °C)	3.2 V
▪ Standard Continuous Discharge Current	0.3 mA
▪ Maximum Continuous Discharge Current	3 mA
▪ Maximum Pulse Discharge Current at 1 sec	50 mA
▪ Nominal Energy	745 mWh
▪ AC Impedance @ 1kHz	11Ω

PHYSICAL CHARACTERISTICS

▪ Typical weight	2.92 g (0.10 oz.)
▪ Li metal content	approx. 0.07 g

OPERATING & STORAGE CONDITIONS

▪ Operating temperature range	-20°C to 60°C (-4°F to 140°F)
▪ Recommended Storage (storage area should be clean, cool, dry and ventilated)	5°C to 30°C (41°F to 86° F)

Delivered capacity is dependent on the applied load, operating temperature and cut-off voltage. Please refer to the charts and discharge data shown for examples of the energy/service life that the battery will provide for various load conditions.

This data is subject to change. Performance information is typical. Contact Hamer for the latest information.

TYPICAL APPLICATIONS

- Medical devices
- Security devices
- Fitness devices
- Watches
- Calculators
- Wireless sensors
- Key-Fobs & Trackers

60086-4 IEC:2007 EDITION 3.0

Test	Test designation	Observation
A	Altitude	Pass
B	Thermal cycling	Pass
C	Vibration	Pass
D	Shock	Pass
E	External short circuit	Pass
F	Impact	Pass
G	Crush	Pass
H	Forced discharge	Pass
I	Abnormal charging	Pass
J	Free fall	Pass
K	Thermal Abuse	Pass

WARNING

- Fire, explosion and burn hazard
- Do not recharge, short circuit, crush, disassemble, heat above 100 °C (212 °F), incinerate, or expose contents to water

Warning! Keep batteries away from children!

- Always keep your batteries away from children to prevent swallowing.
- If ingestion does occur, however, be aware that initial symptoms may be similar to other childhood illnesses such as coughing, drooling and discomfort.
- Battery ingestion hotline (860-498-8666)



130 Bush Road
Albany, 0632
Telephone: 0800 239 239
www.hamer.co.nz

Delivered capacity is dependent on the applied load, operating temperature and cut-off voltage. Please refer to the charts and discharge data shown for examples of the energy/service life that the battery will provide for various load conditions.

This data is subject to change. Performance information is typical. Contact Hamer for the latest information.